

## Service Manual

### **ROBOHAND** | DRF Series



**WARNING:** This is a controlled document. It is your responsibility to deliver this information to the end user of the Destaco Robohand product. Failure to deliver this could result in your liability for injury to the user or damage to the machine. For copies of this manual, call your Customer Service Representative at 1.248.836.6700

# DRF SERIES

## Rotary Actuators | Maintenance and Assembly Procedure

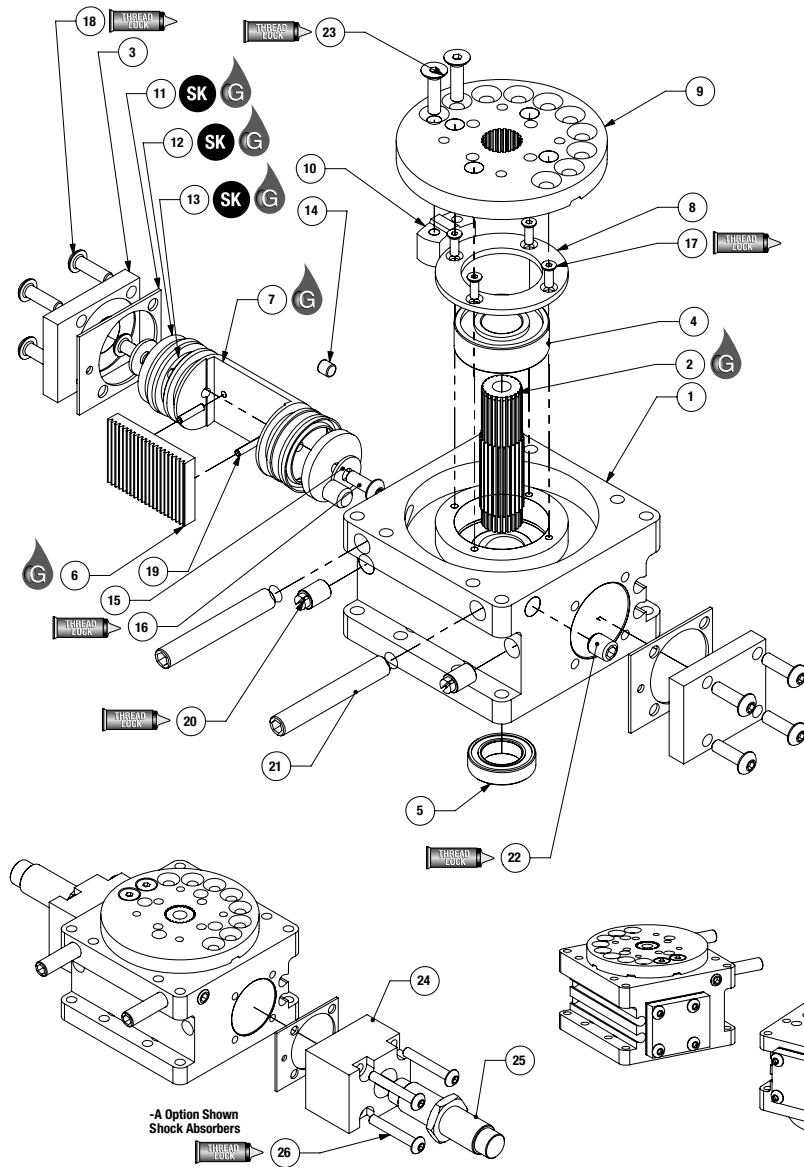

Item	Qty	Name
01	1	Body
02	1	Pinion Shaft
03	2	End Plates
04	1	Upper Bearing
05	1	Lower Bearing
06	1	Rack
07	1	Piston
08	1	Bearing Retainer
09	1	Hub
10*	1	Stop Puck
11	2	Gaskets
12	2	Urethane Bumpers
13	2	U-cups
14	1	Magnet
15	2	Bumper Washers
16	2	Bumper Screws
17	4	Retainer Screws
18	8	End Plate Screws
19	2	Roll Pins
20*	2	Fixed Orifices
21	2	Stop Screws
22	2	Stop Screw Locking Screws
23	2	Stop Puck Screws
24	2	Shock Block
25	2	Shocks
26	8	Shock Block Mounting Screws

### \*NOTES:

- 1) Contact the Robohand Sales Department for a complete spare parts list with order numbers and prices.
- 2) Item #10 Quantity 1 for 180° rotations, all other rotations Quantity 2
- 3) Item #20 not in size -131

### Assembly Procedure

- 1) Press the Upper Bearing #4 onto the Pinion #2.
- 2) Install the Bearing Retainer #8 onto the Pinion #2 and press the Hub #9 onto the pinion: install the Stop Puck #10 onto the Hub with the stop puck Screws #23.
- 3) Assemble the Rack #6 to the Piston #7 with Roll Pins #19.
- 4) Grease the U-Cups #13 and install them onto the Piston #7.
- 5) Press the Magnet #14 into the Piston #7.
- 6) Assemble the Bumper #12, Washers #15 and Bumper Screw #16 onto the Piston #7.
- 7) Lubricate the Body #1 bore and install the Piston Assembly into the body.
- 8) Press the Lower Bearing #5 into the Body #1.
- 9) Locate the Piston assembly so it is aligned with an outer edge of the body.

- 10) Lubricate the Pinion assembly and align the key with the same edge of the Body as the Piston and Press the Pinion into the Body.
- 11) Rotate the Hub Assembly through the full travels and insure that the Piston is correctly located in the Body, adjust the travel of the Piston if necessary.
- 12) Grease the Gasket #11 and install the End Plate #3 onto the Body #1.
- 13) Install the 2 Orifices #20 into the Body #1 screw them in until they bottom.
- 14) Install the Bearing Retainer Screws #17.

### -A Option Assembly Procedure:

- 1) Install the Shock Absorber #25 in to the Shock Blocks #24, use Teflon® tape to seal and tighten the lock nut if shock comes with one.
- 2) Screw the Shock Block onto the Body using the Mounting Screws #26.



Seal Kit Items



Thread Locker



Krytox™ Lubricant



Lightweight Machine Oil



Teflon™ Based Grease



Super Bonder



Third Angle Projection

## Rotary Actuators | Maintenance and Assembly Procedure

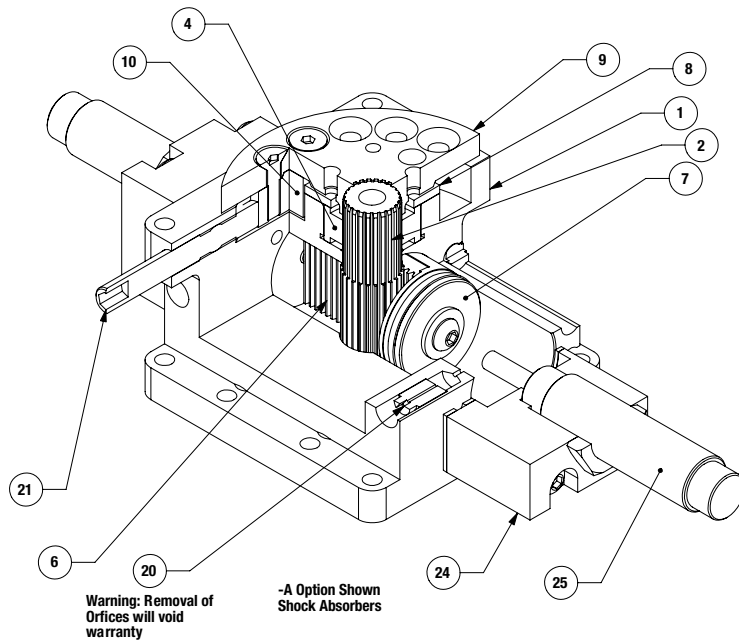

Item	Qty	Name
01	1	Body
02	1	Pinion Shaft
04	1	Upper Bearing
06	1	Rack
07	1	Piston
08	1	Upper Bearing Retainer
09	1	Hub
10*	2	Stop Pucks
20	2	Fixed Orifices
21	2	Stop Screws
24	2	Shock Blocks
25	2	Shocks

**\*NOTES:**

- 1) Contact the RoboHand Sales Department for a complete spare parts list with order numbers and prices.
- 2) Item #10 Quantity 1 for 180° rotations, all other rotations Quantity 2.

Warning: Removal of Orifices will void warranty

-A Option Shown Shock Absorbers

## Accessory Installation & Adjustment Instructions

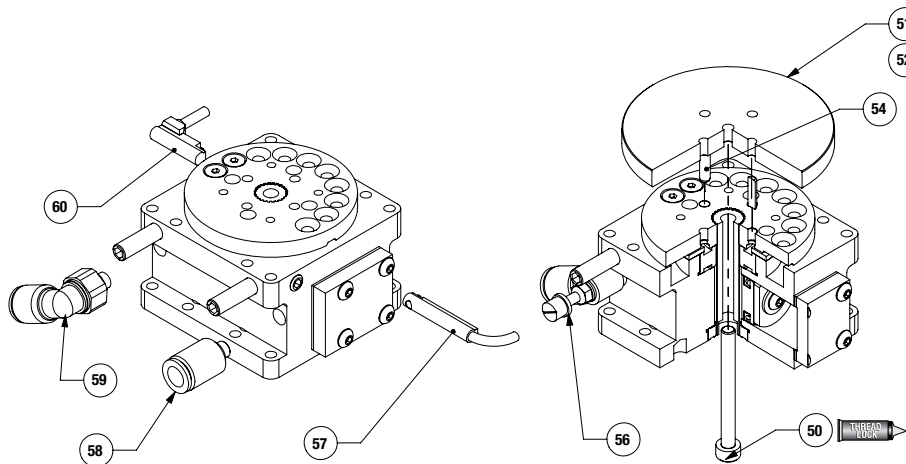

Item	Qty	Name
50	1	Soc Head Cap Screw
51	1	Blank Turntable
52	1	DIRECTCONNECT Turntable
54	2	Dowel Pins
56	1 or 2	Adjustable Flow Control
57	1 or 2	Magneto Resistive Sensor, with Quick Disconnect (short or straight barrel)
58	1 or 2	Plumbing Fitting, Push-in straight
59	1 or 2	Plumbing Fitting, Push-in 90° Elbow
60	1 or 2	Magneto Resistive Sensor, 90° barrel, with Quick Disconnect

**Magneto Resistive Sensors**

- 1) Insert sensors #57 or #60 from either end of the profile slots and set the sensor with the integrated slotted screw set.

**Plumbing Fittings**

- 1) Plumbing fittings #58 & #59 can be used in any airport.
- 2) Flow controls #56 can be inserted and used in any airport.

**Turntable and Output Shaft**

- 1) Insert the two Dowel Pins #54 into the hub (slip fit).
- 2) Attach the turntable #51 or #52, or the output shaft #53 onto the dowel Pins.
- 3) Put thread lock on the Socket Head Screw #50, insert it through the Pinion and tighten.

Seal Kit Items	Thread Locker	Krytox™ Lubricant	Lightweight Machine Oil	Teflon™ Based Grease	Super Bonder	Third Angle Projection



## GLOBAL LOCATIONS

### NORTH AMERICA

#### Corporate Headquarters

Auburn Hills, Michigan  
Toll Free: 1.888.DESTACO  
Marketing: [marketing@destaco.com](mailto:marketing@destaco.com)

#### Global Technology Center

Auburn Hills, Michigan  
Tel: 1.248.836.6700  
Customer Service: [customerservice@destaco.com](mailto:customerservice@destaco.com)

Mt. Juliet, Tennessee  
Tel: 1.888.DESTACO  
Customer Service: [customerservice@destaco.com](mailto:customerservice@destaco.com)

Wheeling, Illinois  
Tel: 1.800.645.5207  
Customer Service: [camco@destaco.com](mailto:camco@destaco.com)

Red Wing, Minnesota (Central Research Laboratories)  
Tel: 651.385.2142  
Customer Service: [sales@centres.com](mailto:sales@centres.com)

### ASIA

Bangkok, Thailand  
Tel: +66-2-326-0812  
Customer Service: [info@destaco.com](mailto:info@destaco.com)

Shanghai, China  
Tel: +86-21-6081-2888  
Customer Service: [china@destaco.com](mailto:china@destaco.com)

Bangalore, India  
Tel: +91-80-41123421-426  
Customer Service: [india@destaco.com](mailto:india@destaco.com)

### EUROPE

Oberursel, Germany  
Tel: +49-6171-705-0  
Customer Service: [europe@destaco.com](mailto:europe@destaco.com)

Sainte Florine, France  
Tel: +33-4-73545001  
Customer Service: [france@destaco.com](mailto:france@destaco.com)

Wolverhampton, United Kingdom  
Tel: +44-1902-797980  
Customer Service: [uk@destaco.com](mailto:uk@destaco.com)

Sant Boi de Llobregat, Spain  
Tel: +34-936361680  
Customer Service: [spain@destaco.com](mailto:spain@destaco.com)

Uithoorn, Netherlands  
Tel: +31-297285332  
Customer Service: [benelux@destaco.com](mailto:benelux@destaco.com)